

Properties of anchor grouts in a confined state

Eur.Ing. A D BARLEY

Director of Engineering, Keller Colcrete, Wetherby, UK

1.0 INTRODUCTION

The ability of an anchor grout to set, gain strength and transfer the entire load of the anchor from the tendon to the ground is an essential requirement of all grouted ground anchors. The current recommended modes of testing of anchor grout involve bleed tests, shrinkage tests and cube tests. Subject to the results lying within limits specified in BS8081 (Ref. 1), the grout may be deemed to be acceptable. It is interesting to note that the UCS requirements of anchor grout have gradually risen over the years. - For example 28N/mm² (Littlejohn 1972), 35N/mm² (Mascardi 1973), 40N/mm² (BS8081-1988). (This information is presented in "Rock Anchors state-of-the-art" (Ref. 2) which provides an excellent informative document on anchor grouts).

However, these unconfined compression strength (UCS) test results provide no information or guidance as to the actual values of stresses mobilised or available when the load is transferred, normally by shear and direct bearing through the grout body in its confined state within the anchor borehole. Furthermore, it is frequently the case that in anchoring and other geotechnical works the actual mix despatched from the ground surface changes considerably prior to its setting in small volumes often of irregular shapes. The shapes and volumes in which the grout sets are rarely comparable with those of a test cube, but more generally form thin sometimes disrupted planes, mixed with permeated soil material, and at the same time contained and confined by adjacent soils or rocks. The application of pressure is frequent during grouting operations and, when pressure is applied to grout contained within water permeable ground or fissured rock, water is squeezed from the grout causing the water/cement ratio to become considerably reduced from that originally mixed and injected.

2.0 GROUT IN DIRECT SHEAR IN A CONFINED ENVIRONMENT

Whilst carrying out research to establish the capacity of underreams constructed within a borehole in weak rocks (Ref. 3) a test method was developed to determine the shear capacity of grout along a cylindrical shear plane of identical diameter to that of the in-situ borehole (Fig 1). The cylindrical diameter was 114mm and the axial lengths of the shear planes were 50, 100, 200 and 300mm in order to simulate the length of the underreams formed in the borehole wall. Each test was carried out in a grout mass, surrounded by helical steel reinforcement to simulate a fully confined state and to isolate failure to each individual test in the grout mass. The pull-out load was transferred into the simulated anchor body using prestressing strands. These strands were individually deformed (strand node) to ensure that the full load could be transferred into the grout body without pull-out of strand occurring before grout shear failure was induced along the cylindrical plane. The grout was mixed in a high speed paddle mixer

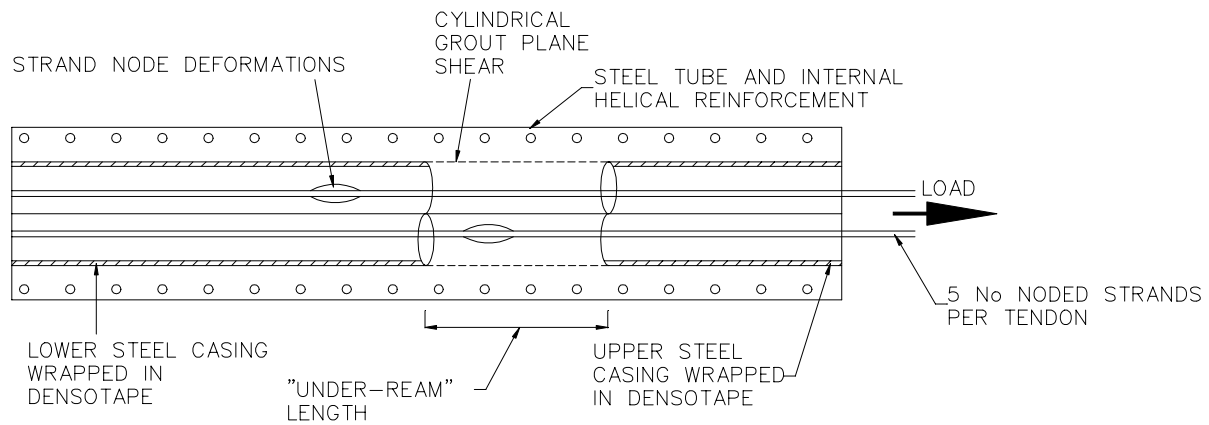

Fig 1. Determination of shear strength of grout along a cylindrical shear plane

(rather less efficient than a modern colloidal mixer), in a water/cement ratio of 0.45 using Rapid Hardening Portland cement.

All tests were carried out using a calibrated hollow ram jack which loaded the protruding strands. These tests were carried out 21 days after grouting, and relevant cubes were crushed the same day to provide UCS data. Results are presented in Table I.

The exhibited values of ultimate shear stress of the grout ranged from 12.90 to 19.94N/mm², whilst unconfined compressive strength of the grout of the same age ranged from 49.5 to 67.8N/mm². Shear stress ranged from 22% to 33% of the UCS but, based on these limited results, there is no evidence of a linear relationship. It has been suggested that a linear relationship may exist between shear stress and UCS values up to compression strength of 21N/mm², but thereafter the increase in bond or shear capacity with increase in UCS becomes small and non-linear (Ref. 2). Bond stresses mobilised at the deformed strand/grout interface were up to 3.58N/mm² with no indication of pull-out.

Table 1 The ultimate shear stress of anchor grout along a cylindrical failure plane.

Test No.	Length of shear plane mm	UCS of grout at 21 days N/mm ²	Failure load at 21 days kN	Ultimate shear stress N/mm ²
1A	50	62.6	264	14.75
1B	99	56.8	517	14.58
1C	200	58.4	940	13.12
1D	300	59.3 av.	No failure	-
2E	0.98	59.8	700	19.94
2F	100	49.5	462	12.90
2G	0.99	67.8	591	16.66
2H	100	59.0 av.	554	15.47

Investigation work reported by Raison (Ref 3) established the failure bond capacity of a 80mm long 90mm dia corrugated duct cast within cementitious grout at 12 to 13N/mm². This sharp nosed duct profile required shearing of grout over approximately 90% of the cylindrical

failure plane, thus indicating a grout shear capacity of 14N/mm^2 consistent with those reported above.

A repeat of this test has been carried out more recently to investigate the shear capacity of encapsulation grout. This proprietary grout, which incorporated a fine sand filler, exhibited a considerably higher shear capacity than that of neat OP cement. The ultimate shear stress along a 100mm cylindrical length with a diameter of 114mm attained 25.4N/mm^2 , whilst the UCS of the mix at 22 days age of the test was 57N/mm^2 .

3.0 GROUT IN DIRECT BEARING IN A CONFINED ENVIRONMENT

3.1 A circular bearing plate mounted on a sleeved steel bar

During research to investigate the load transfer mechanism from a circular bearing plate above an end nut on a sleeved Macalloy bar, high direct bearing stresses were induced (Ref 4 Fig 2, Table 2). Loss of load was followed by pull-out from the grouted boreholes in sandstone and revealed the formation of a cone of grout above the bearing plate. The combined plate and grout cone had penetrated through the highly stressed, confined, grout column by a tunnelling mode inducing shear and crushing of the highly fractured borehole anchor grout. Direct bearing stresses on the plate attained up to 308N/mm^2 without compressive grout failure at the plate surface. The conical tunnelling failure mechanism induced extremely large lateral stresses within the fractured grout. As a result, the actual bond stresses at the grout rock interface over short bonded lengths (260mm to 920mm) also attained extremely high values; up to 10.38N/mm^2 . (The occurrence of this tunnelling mechanism above an end plate was appreciated in the industry in the early days of anchoring, and the incorporation of a simple compression tube above the end plate was available in the sixties. Further refinement continued through the seventies to develop more sophisticated compression tube systems which allowed protection of steel tendon against corrosion).

3.2 A compression component in a removable multiple anchor

Research work in the development of the removable anchors (Ref. 5) required a large number of pull-out tests to investigate the capacity of different compression load transfer components (Fig 2c & d). These tests were carried out within the confinement of steel gun barrels which, after failure, were split open to examine the precise failure mode. A number of neat cementitious grouts, proprietary cement grouts containing filler and aggregate, and resin grouts also with aggregate content were investigated. Direct bearing stresses as high as 1000N/mm^2 have been achieved in these trials.

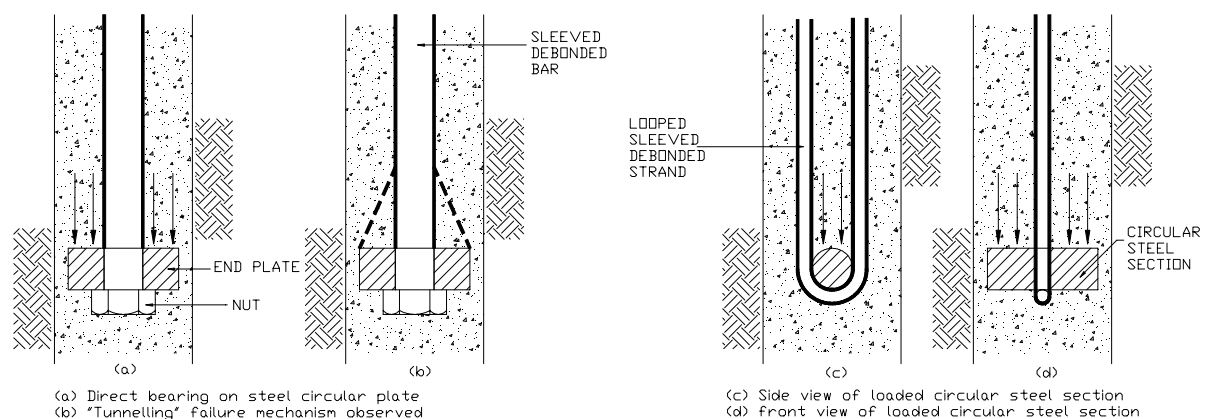

Fig 2. Loading transfer mechanisms from a circular steel section to anchor grout which established values of direct bearing capacity.

Table 2 Direct bearing stress mobilised on end plates without bearing failure.

Test No	Grouted length above plate mm	UCS of grout N/mm ² (at 28 days)	Failure load kN	Direct bearing stress N/mm ²
13	500	54	950	266
14	530	54	1100	308
15	920	42	1000	280
16	570	42	295x	83
17	260	58	780	218
18	390	58	680	190
19	340	56	770	215
20	490	56	1000	280

Diameter of sleeved bar = 50mm. Plate dia = 80mm. Borehole dia = 92mm
Plate Area = 3574mm² x = evidence of grout contamination.

3.3 Method of testing the direct bearing capacity of grout in a confined environment

Research and development of the removable anchor system by gun barrel tests established a range of pull-out capacities which were heavily influenced by the direct bearing capacity of the selected grout. Accordingly, in order to provide a more cost effective mode of determining the direct bearing capacity of the grout in a confined state, a simple test method which allows use of normal cube testing equipment, has been evolved.

Clearly, direct bearing capacity is heavily influenced by the degree of confinement and the shape of the confined grout, but it was necessary to establish a “standard” by which performance could be judged. Inevitably, a circular steel tube similar to that used for the gun barrel, defined the shape. Initial tests were carried out to investigate difference in performance using 12mm thick M.S. tubes with internal diameters of 105 and 130mm. Sample heights were varied from the diameter to half diameter of the tube, and direct bearing plinths, which “punched” into the grout, were of 25, 37 and 50mm diameter. Eventually a “standard”, utilising readily available 105 ID steel tube of height 50mm, and applying the direct bearing load to the sample with a plinth of 50mm diameter, was chosen. In a majority of cases, the load capacity of the cube crushing equipment exceeded the load requirements of the test. Failure was observed after approximately 25mm of plinth penetration (half the plinth diameter). Results investigating the direct bearing capacities of a neat OPC grout and a proprietary grout, and comparison with UC strengths are presented in Fig 3.

Calculations have been carried out to confirm that the degree of confinement provided by the “elastic” steel ring is in fact compatible with a range of ground conditions in which an anchor may be installed. Use of cavity expansion theory developed by Yu and Houlsby (Ref. 6) suggests strong similarity between steel tube confinement and confinement provided by a dense to very dense sand over a range of depths (Fig 4).

The limited test data available has not identified any apparent relationship between grout cube strength and grout direct bearing strength in a confined condition but bearing in mind the vastly different failure modes (Photo 1), this is perhaps to be expected. Ultimate compressive

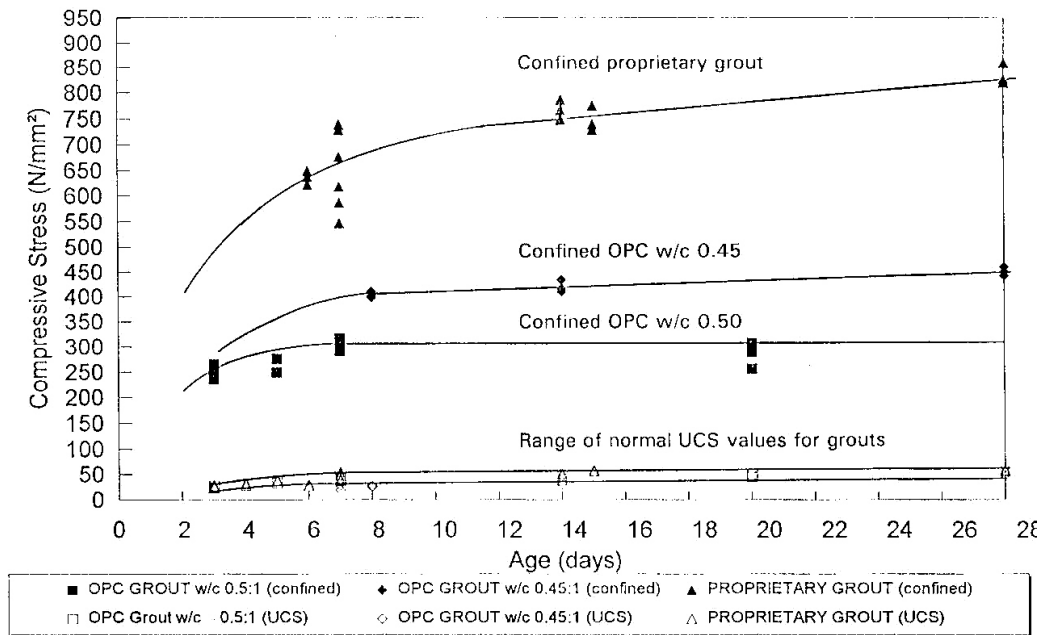

Fig 3. Comparison of the direct bearing capacity of fully confined grout samples with standard unconfined compressive strength data.

stresses as high as 800N/mm² have been exhibited by confined grouts, whilst the compressive stresses of samples of the same unconfined grout at the same age have ranged from 40 to 70 N/mm².

4.0 GROUT IN BOND IN A CONFINED, PARTIALLY CONFINED AND NONCONFINED ENVIRONMENT

In essence, the majority of gun barrel tests carried out to investigate tendon and encapsulation pull-out capacity (Ref 7) for the design of load transfer systems, have been carried out in “fully” confined conditions. Liaison with the University of Sheffield led to the investigation of the influence of lateral confinement of the grout column on the pull-out capacity of short simulated encapsulations.

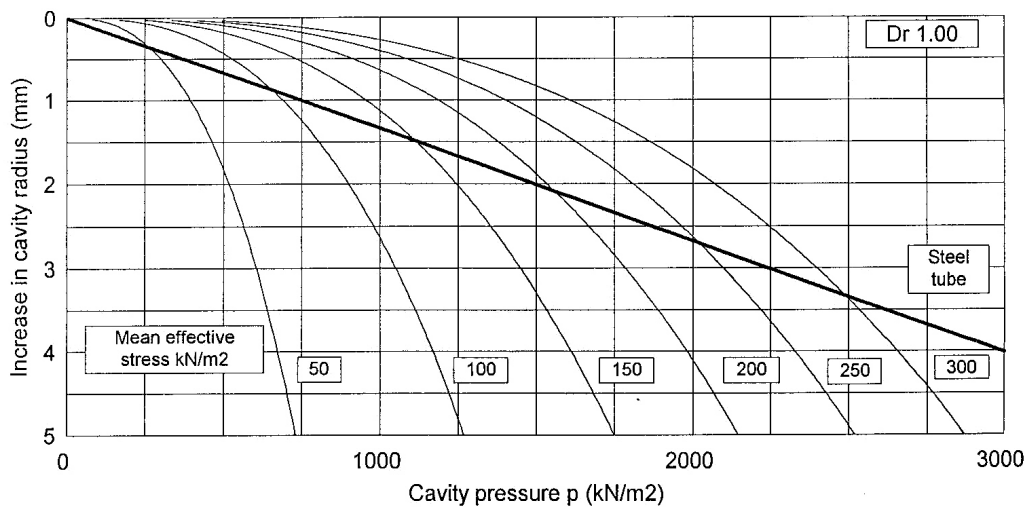

Fig 4 Comparison of confining pressure provided by the steel tube with that of a dense sand using Yu & Houlsby’s cavity expansion theory

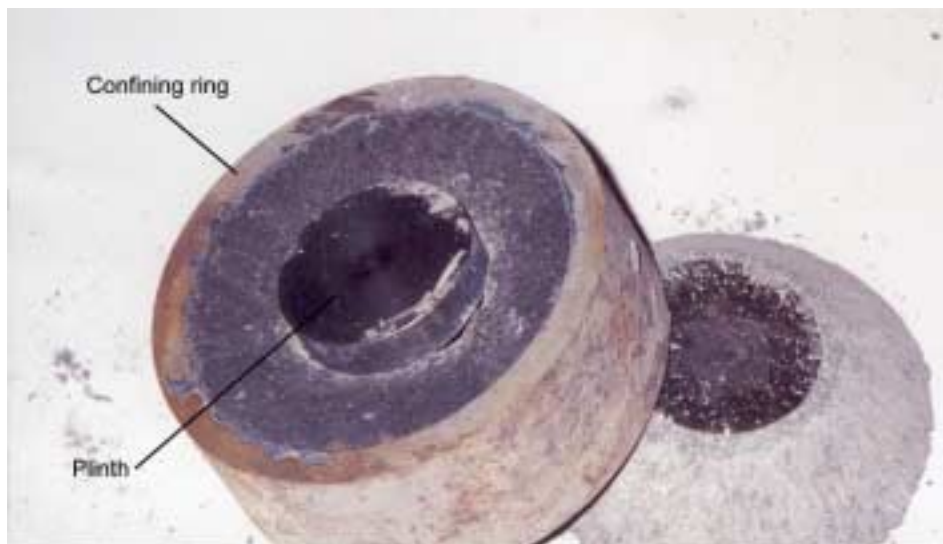

Photo 1 View of steel confining ring around test specimen and 50mm loading plinth. Failure shape is conical and lateral forces across this cone face force steel ring upwards at failure.

A 50mm diameter steel bar was machined on its outer surface to form corrugations similar to those on the outer face of an encapsulation duct or compression tube (Fig 5). The simple arrangement ensured omission of the rather complex load transfer mechanism present in a normal internally grouted encapsulation system.

The bar arrangement was centralised in a variety of short confining tubes of 100 to 155mm diameter, and consistently grouted in place with a grout of water/cement ratio of 0.4. After the water curing of the grout to attain UC strengths of 30 to 38N/mm² and tensile strengths ranging from 2.9 to 3.7N/mm² the short “gun barrels” were installed in a loading apparatus which was devised to fit into a hydraulic loading machine (Fig 6). This allowed the bar to be loaded at a chosen constant rate of load application, whilst the associated monitoring of displacement and radial expansion of the confining tubes at three levels could be carried out. This concept is supported by information on Figure 7 which shows the pull out capacity increasing with the increase in annulus thickness (tube diameter) for all tested bond

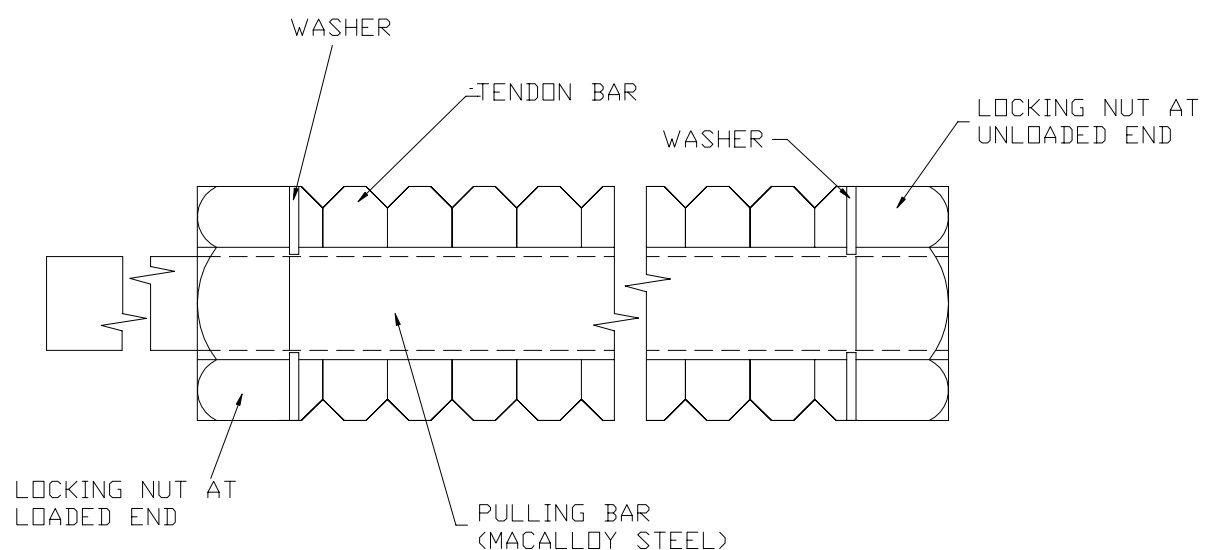

Fig 5. Steel bar machined to produce outer surface compatible with that of an encapsulation system (after Y.C.Lo)

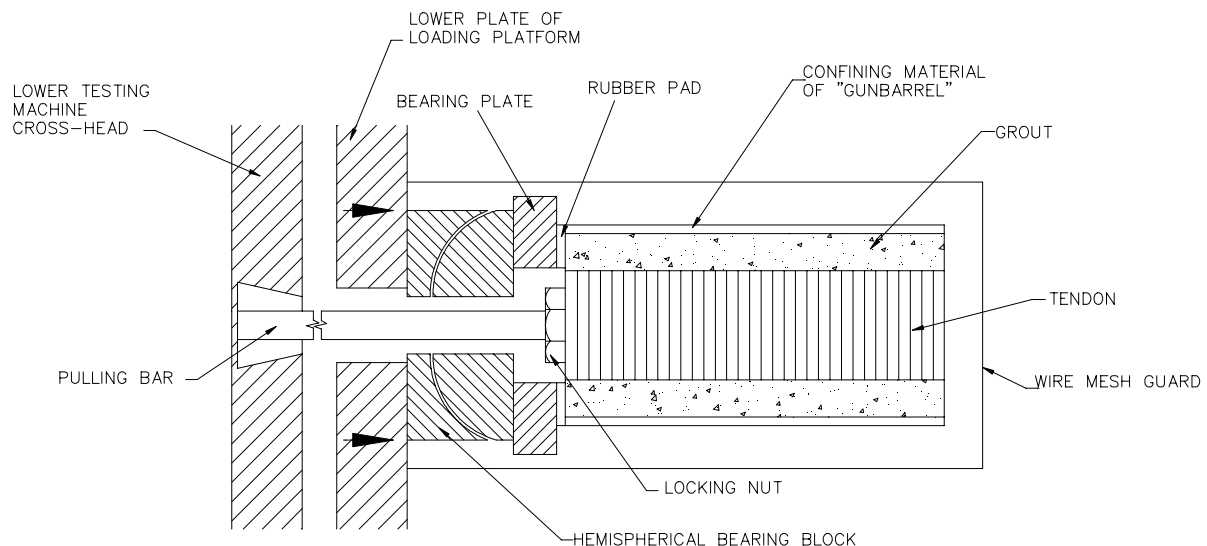

Fig 6. Short “Gun barrels” containing simulated encapsulation tested in hydraulic loading machine (after Y.C.Lo)

lengths. Pull-out capacity (11 to 25kN) increased only nominally with increase in bond length (Fig 7) whereas, if it had been totally controlled by the tensile capacity of the grout annulus the increase would have been greater. Mobilised bond stresses ranged from 0.4 to 1.8N/mm².

The tested bond lengths of the bar were 75, 150 and 200mm in each “gun barrel”, and the “gun barrel” or confining tubes consisted of rubber hoses with several degrees of stiffness, and steel tubes with small differences in both diameter and wall thickness. Prior to the execution of the tests, the elastic properties of all the rubber hoses had been fully investigated by calculation and internal pressure loading to establish their elastic moduli. Based on calculations by the researcher, the three simulated elastic moduli were representative of soft to very soft soil condition. Further calculations by the researcher using the known elastic modulus of steel and the poisons ratio, established that the three steel tubes provided constraint, representative of a weak rock/dense sand condition.

31 pull-out tests were made, categorised into three classes of confinement: zero, partial and full confinement. The zero confinement tests all failed at relatively low loads by explosive

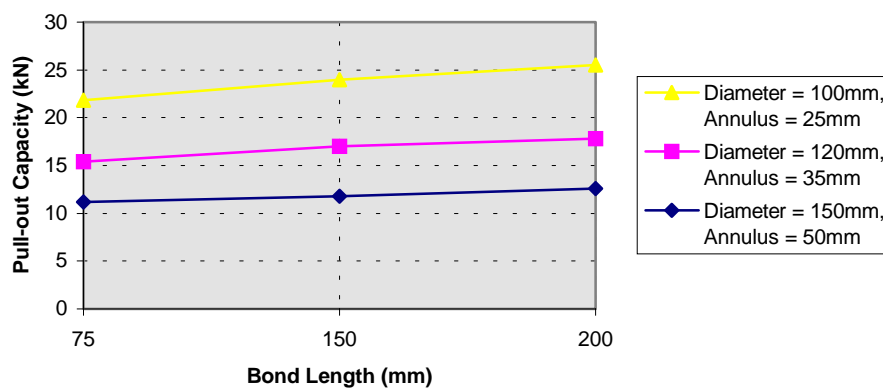

Fig 7. Variation in pull-out capacity with diameter of tube and with bond length (unconfined tests) (after Y.C.Lo).

splitting of the grout column into four equal segments. The failures occurred when the bursting stress developed at the steel grout interface exceeded the tensile capacity of the grout

The partial confinements tests also failed entirely by grout column splitting, albeit at somewhat greater loads than encountered in the zero confinement tests (18 to 49kN). In these tests, the bursting forces induced at the steel grout interface were restrained not only by the tensile capacity of the grout annulus, but also by the confinement provided by the soft soil simulated. Average bond stresses exhibited ranged from 1.2 to 2.2N/mm².

The full confinement tests all exhibited a tendon pull out mechanism by shear of the grout along the encapsulation diameter. Pull-out capacity (53 to 180kN) increased proportionally with increase in bond length, and capacity increased with increase in elastic modulus values representative of the ground confinement, but capacity was not apparently influenced by the grout annulus thickness. The restraint provided by the tensile capacity of the grout would be small in comparison with the ground confinement. The monitoring of increase in diameter of the “gun barrel” during loading allowed calculation of the actual radial pressure induced in the steel tube to restrain the bursting forces caused by the tendon pull out.

Fig 8 confirms the generated radial pressure increase with increase in load in each test, and shows that the greater the confinement (increase in elastic modulus of the ground), the greater the pull out capacity. Average bond stresses as high as 4.4 to 5.7N/mm² were demonstrated over these short length confined tests.

It should be appreciated that all these pull-out tests involved only very short simulated encapsulation lengths and, whether carried out by shear tube (compression loading) or normal tensile encapsulation load transfer mechanism, the occurrence of progressive debonding mechanism would not be present; i.e. in pull-out tests on longer full scale encapsulations, whether confined or partially confined, pull-out capacity is unlikely to increase in proportion to increase in bond length. However, the test results do provide a major contribution to the understanding of the influence of the degree of confinement of the grout column by the ground on the load transfer from tendon or encapsulation to the anchor grout. It should be noted that, in full scale anchors in weak rocks, where failure has stemmed from a combination of low rock

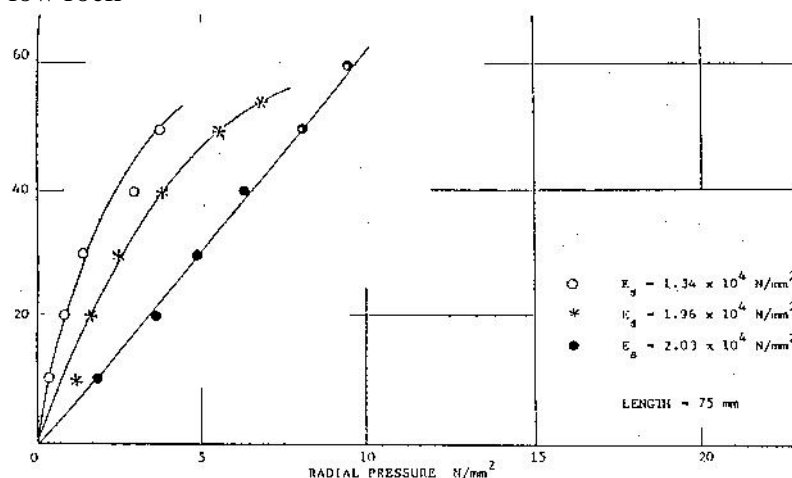

Fig 8 Increase in radial pressure with increase in load and increase in pull out capacity with increase in elastic modulus (after Y C Lo).

bond and low confining pressure (weak mudstone), on extraction the encapsulation alone will be withdrawn from the broken grout. Television inspection of the bore may indicate solely encapsulation pull-out and the evidence of bursting may not be apparent (Ref 8). Currently there are no special load transfer mechanisms available to accommodate load transfer with reduced bursting forces but the solution may involve either the incorporation of spiral reinforcement, the use of high tensile capacity resins, or the acceptance of low load capacity in ground conditions where only low confining pressures exist (low elastic moduli).

5.0 CHANGE IN GROUT CONSISTENCY IN THE ANCHOR BODY

The exhumation of the grout column in the fixed length of pressure grouted anchors has allowed analysis of the cement content of the in-situ grout (Ref 9). It is fully acknowledged that the application of pressure to grout surrounded by a water permeable soil causes the loss of some of the excess water from the grout into the soil. "Excess water" is that quantity of water in the grout mix necessary to reduce viscosity and allow pumpability, but not required for the hydration of the cement particles. Hence the water/cement ratio of the grout within the bore has been known to reduce from ranges of 0.5 to 0.34, and from 0.45 to 0.30. In these circumstances the strength of cured grout in the anchor body is not only grossly enhanced by the confinement provided by the soil but also is rendered considerably greater than that of the grout installed at the surface as a result of its reduced water content. Investigation of the direct compressive and shear strengths of these reduced w/c ratio grouts in a confined state using the test methods detailed in 2.0 and 3.3 is about to be carried out.

6.0 SUMMARY

During the loading of a ground anchor the load transfer mechanisms between the tendon and the grout, and the grout and the borehole wall, demand the utilisation of extremely high values of shear and compressive stresses within the body of the confined grout. Normal unconfined compressive tests on anchor grouts provide no information on the stresses available for mobilisation in the anchor bore grout, but a simple new test system such as that discussed above, simulating the confinement of a grout column in dense to very dense sand or moderately weak rock, provides an indication that compressive stresses in the range of 200 to 800N/mm² are available in the anchor grout body. These values are an order of magnitude greater than UCS values. Hence it should be appreciated that UCS test values, while entirely appropriate for basic Quality Assurance, are in no way reflective of the actual strength available in-situ. The presence of such high values is supported by the very satisfactory performance of removable multiple anchors, which mobilise high stresses of both direct compression and shear.

Other simple tests on confined grout indicate that direct shear strength may range from 12 to 20N/mm² in normal anchor grout, and 25N/mm in proprietary encapsulating grouts. These values considerably exceed the bond stress generally available at the grout/ground or rock interface. This highlights the enormous benefits to be obtained by the pressure grouting of weak fissured rocks (chalk and mudstone) since the load contribution of a grouted fissure (the grout of which must be sheared prior to pull-out) may equate to the capacity of the non-fissured bore lengths of 50 to 100 times the fissure width.

In water permeable strata, the application of pressure whilst grouting has been shown to reduce the w/c ratio of the anchor grout from the 0.45 to 0.5 range to 0.30 to 0.34 range. This occurrence further increases the in-situ strength of the anchor grout such that compressive and shear capacity may be in excess of those values reported above.

REFERENCES

- Ref. 1:* BS8081, Code of Practice for Ground Anchorages - BSI publication (1989)
- Ref. 2:* Littlejohn G S, Bruce D A. "Rock Anchors - State of the Art". Foundation Publications 1977.
- Ref.3:* Raison, C.A. (1987) "Ground Anchorages: Component testing at the British Library, Euston. Proc of Institution of Civil Engineers, Part 1, 1987. June 615-626.
- Ref. 4:* Barley, A.D. "A study of underreamed anchors in weak rocks and associated bond transfer mechanism". Thesis Marshall College, Aberdeen, 1976.
- Ref. 5:* Barley, A.D. "Development of removable anchor systems and components, 1996". Keller Colcrete Report - Confidential.
- Ref. 6:* Yu and Houlsby (1991), "Finite cavity expansion in weak soils: Loading analysis" Geotechnique 41 No.1.173-183
- Ref. 7:* Yuen-Cheong Lo. "Investigation of the effect of lateral restraint on ground anchor failure at the grout/tendon interface". Thesis, University of Sheffield, Civil Engineering 1979.
- Ref.8:* Barley, A.D. "Television inspection of Barnsley trial anchor borehole in mudstone after tendon withdrawal, Barnsley Ring Road, 1991". Confidential.
- Ref. 9:* Barley, A.D. "The effect of application of pressure in a ground anchor and inspection of exhumed grout bodies". Ground Engineering 1997.